

SÖVDA

SÖVDA

Better Design.
Better Coffee.

GREEN COFFEE SORT: 500 KG/HR

ROAST COFFEE SORT: 250 KG/HR

ACCURACY: 99.5%





Better Design. Better Coffee.

Spending way too much time and attention trying to sort out foreign matter, quakers and burnt beans? Sovda machines, made for specialty roasters, make sorting and packaging easier, faster and more precise.

It's time to strive for excellence and efficiency

Are You a Specialty Coffee Roaster? Is your team spending way too much time and attention trying to sort out quakers, burnt beans, and foreign matter out of your specialty coffee? We want to help you take a leap forward towards excellence and efficiency by providing color sorting technology for your roasted and green beans. Let us show you how easily our advanced color sorting technology can benefit your coffee business!



S O V D A
PEARL MINI

—
*Is your
roast master spending
too much time and attention
picking quakers?*



TRADITIONAL WAY

HAND-SORTING

TIME CONSUMING

LIMITATION OF HUMAN EYES

SPECIAL GREEN COFFEE
WITH FEW DEFECTS

QUALITY CONTROL
ISSUES ON COFFEE



NEW WAY

S O V D A

250KG / HOUR

99.5% ACCURACY

SORT UP TO 500KG
GREEN COFFEE / HOUR

DESIGNED FOR
SPECIALTY COFFEE

About the Brand

“
We want to help you take
a leap forward towards
excellence and efficiency.”



S O V D A

With backgrounds touching every aspect of the specialty coffee industry, we've seen the pain points specialty roasters work through day to day and the lack of equipment made to meet their needs.

We've also been witness to the often-difficult plight of coffee farmers and that was the spark of our mission driven innovation. We first developed sorting technology to help farmers, eventually realizing we could make more of an impact by applying this technology to helping specialty roasters add value to their product through a more efficient process that produces a more perfect roast.

Sovda machines are designed to be aesthetically pleasing and simple to use. Our products have been developed and tested with the Torch Coffee Research & Development Lab. The Pearl Mini, Sovda Lift and Precision Fill are designed to seamlessly integrate into the existing operations of Specialty Coffee Roasters.

Not only did we apply smart technology and elegant Scandinavian design principals to the specific requirements of specialty roasters, we designed our supply side and manufacturing model to offer well-supported, quality machines at prices specialty roasters can afford.

Our Brand Promises...



Engineered for Specialty Coffee Roasters



Quality Materials and Workmanship



Leveraging Technology



Elegant Scandinavian Design



Affordable Price



Fanatical Customer Support



3 steps to sort

1 ENTER YOUR PARAMETERS.

Create your profile or select an existing one. Check the expected outcome in real time with automatic mode and adjust



2 START SORTING YOUR BEANS.

Beans are loaded directly from your roaster via a loader connected to the hopper

Press start, the optical cameras will recognize good beans from reject based on the color spectrum you selected and ejects them using targeted air blasts.

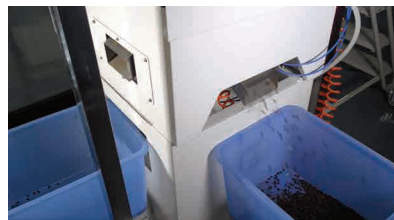

3 YOUR BEANS HAVE BEEN SORTED. ENJOY!



Sample Sort

pearl mini sample sort of the green & roasted bean in 6 min



GREEN COFFEE
50KG



sorted bad beans



sorted good beans



ROASTED COFFEE
25KG



sorted bad beans



sorted good beans

SORTING CAPACITY (PER. HOUR)

250KG - ROASTED

500KG - GREEN

**BEAUTIFUL FOOD-GRADE
STAINLESS STEEL
& PAINTED METAL**

available in white or black



TWO OPTICAL CAMERA

combined with 32 air splash valves
to color sort accurately & quickly

AUTOMATED SYSTEM

for self maintainance purposes.

EASY TO LOAD, thanks to a hopper that is
available in 3 different sizes (60, 80 & 100 L),
depending on your production capacity.
Customisation are available upon request.

USER INTERFACE

4" COLOR DISPLAY CONTROL PANEL

SMART OPERATION via mobile devices

SYSTEM MEMORY can store color sorting
profiles for repeated use, according to your
needs.

1 YEAR WARRANTY,
with customer support assistance
through phone call / email

DIMENSIONS

900(W) X 1100(D) X 2250(H) MM

OUR STANDARD BASE ADDS
400 MM OR 250 MM ADDITIONAL HEIGHT

WEIGHT

450 KG

ELEC. SUPPLY

220 V 7 amp

3WIRE
(1 HOT, 1 NEUTRAL, 1 GROUND)

FOR USA 110 ONLY
WILL PROVIDE TRANSFORMER

COMPRESSOR

5.5 - 7.5 KW
23 CFM at 90 PSI
or .8M³ at .3MPA

REFRIGERATOR TYPE DRYER

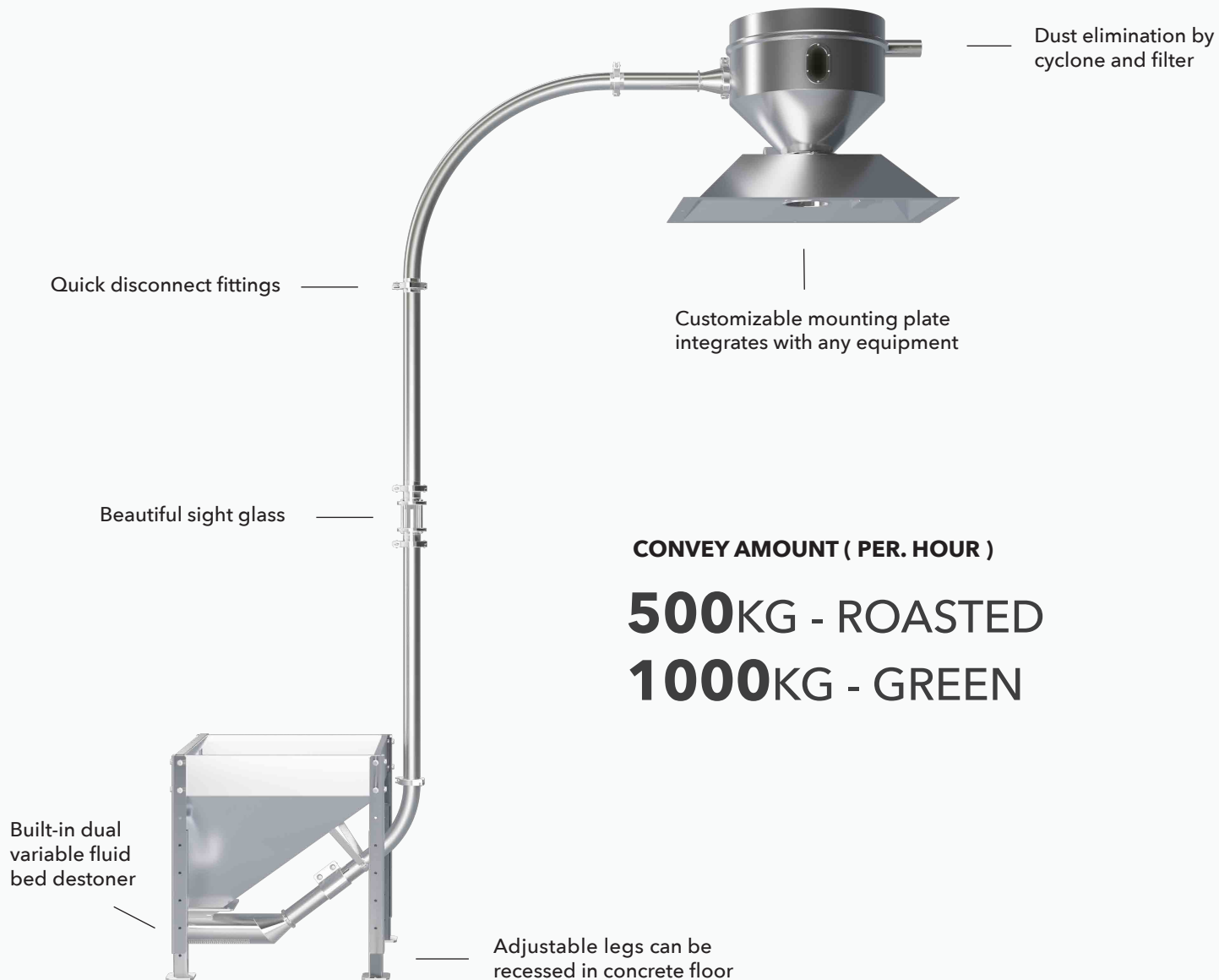

CONVEY AMOUNT (PER. HOUR)

500KG - ROASTED

1000KG - GREEN

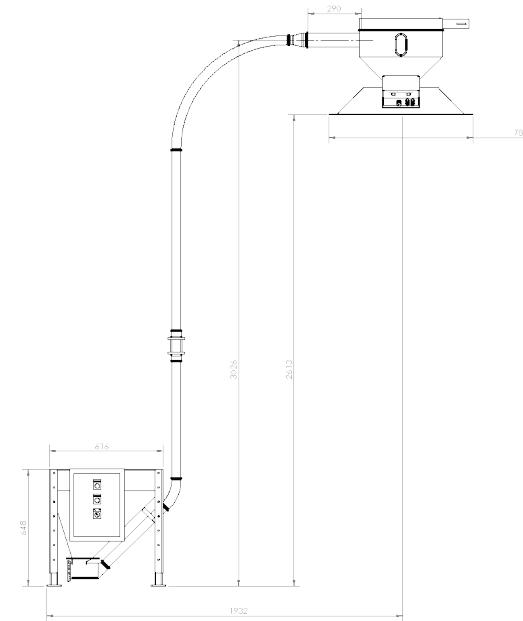

PRODUCT SPECS

- Conveys 500/kg roasted coffee and 1000/kg green coffee per hour
- .51mm 2" pipe
- 60 liter hoper, 40-80cm adjustable height
- All food grade stainless steel

SHIPPING SPECS

Weight: 180kg (397lbs)

Volume: 1.37 m3

Dimensions:

Box 1: 134(D) x 87(W) x 101(H) cm
(54 x 34 x 40 in)

Box 2: 164(D) x 26(W) x 51(H) cm
(65 x 10 x 20 in)

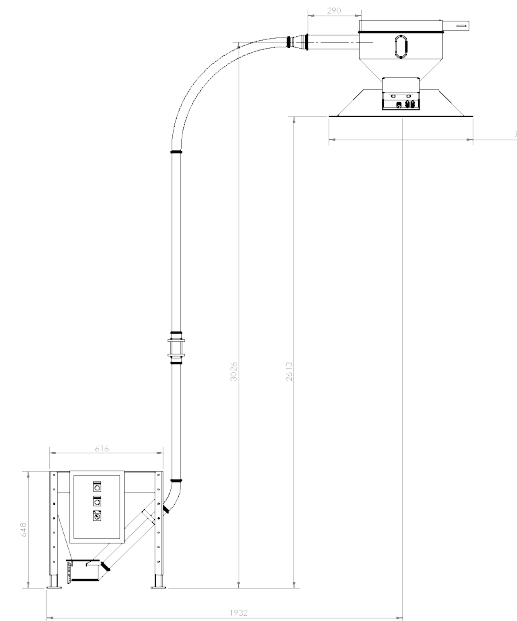
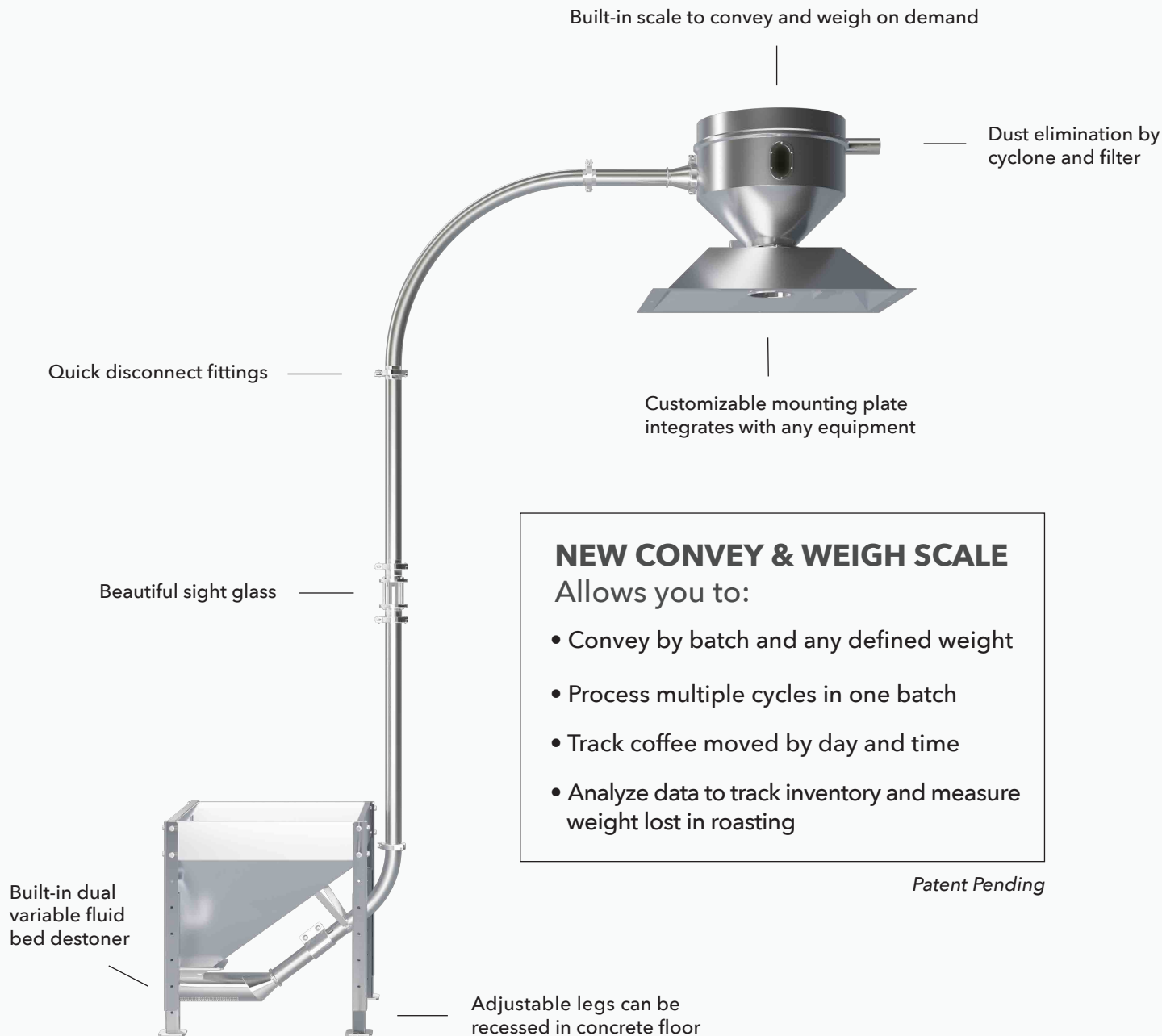

PRODUCT SPECS

- Conveys 500/kg roasted coffee and 1000/kg green coffee per hour
- .51mm 2" pipe
- 60 liter hoper, 40-80cm adjustable height
- All food grade stainless steel

SHIPPING SPECS

Weight: 180kg (397lbs)

Volume: 1.37 m3

Dimensions:

Box 1: 134(D) x 87(W) x 101(H) cm
(54 x 34 x 40 in)

Box 2: 164(D) x 26(W) x 51(H) cm
(65 x 10 x 20 in)

TOUCH SCREEN CONTROLS

Software records history of bags filled

Cycle mode: enter a set number of bags and system stops when you hit the target

INTERCHANGEABLE FILLER HEADS
for 100-2200g size bags

Removeable base



BUILT-IN SCALE
to weigh and fill coffee within +/- 2g accuracy

Fills 6-8 bags per minute

Filling is controlled with foot pedal (included)

1 YEAR WARRANTY
with customer support assistance through phone call / email

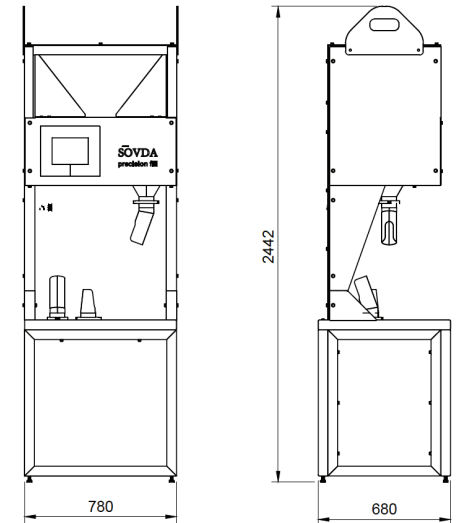

PRODUCT SPECS

- Fills 100-2200g (4oz to 5lbs) size bags
- 60 liter hopper
- 2442mm height (w/ base), 240kg weight
- Food grade stainless steel and painted metal
- Power: 60hz , Electric supply: AC 110v

SHIPPING SPECS

Weight: 270kg
Volume: 1.32 m3
Dimensions: 94.5(D) x 89(W) x 158(H) cm

WEIGHS

INDIVIDUAL BATCHES
of coffee for roasting

UP TO 8 different green
coffees for pre-roast blends

coffee as it is loaded and
TRACKS INVENTORY

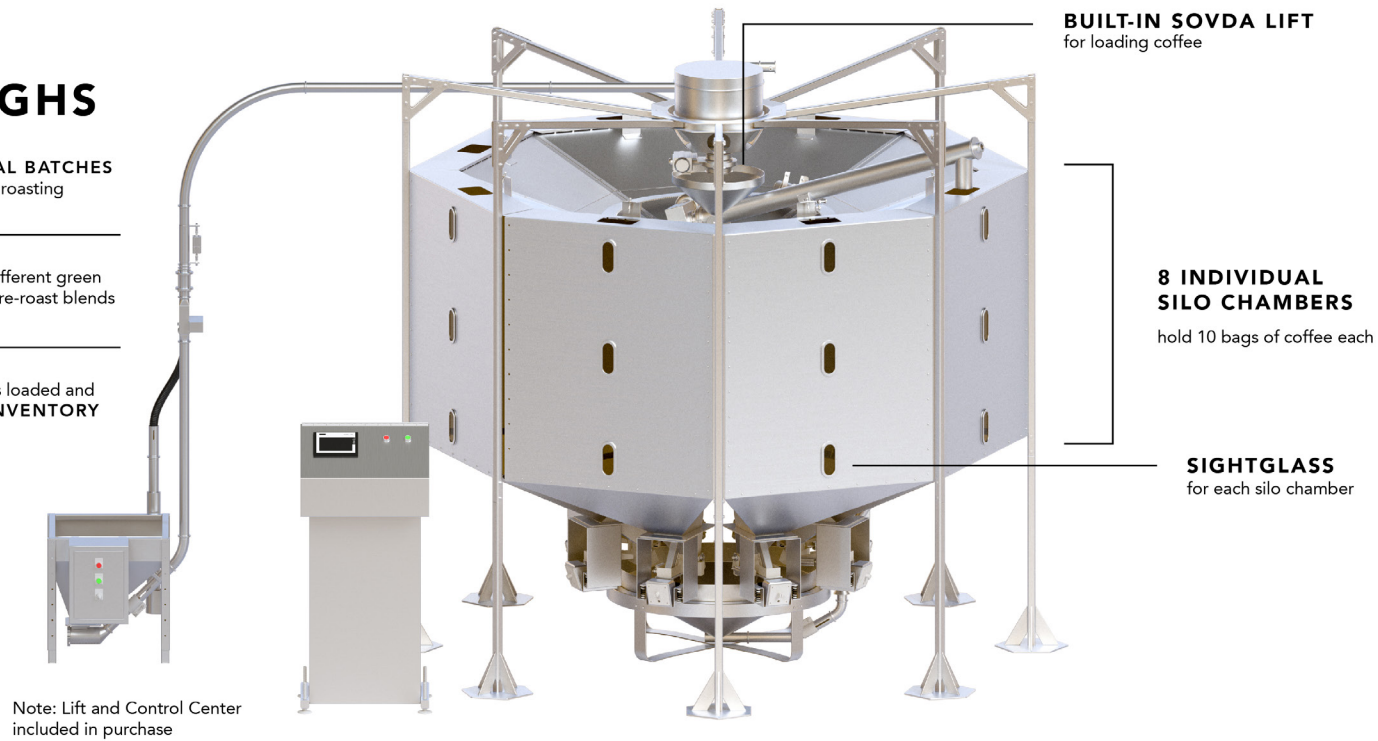

**STORAGE
CAPACITY**

GREEN
4800kg (~10580lbs)

ROASTED
2400kg (~5290lbs)

WIDTH
2.9M (9' 8")

HEIGHT
2.99M (9' 10")

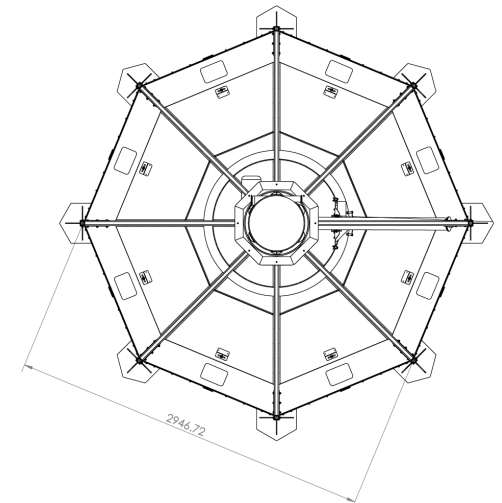

FAQ

What size roastery is Sovda equipment made for?

With specialty coffee roasters in mind, our equipment is made to integrate with 15 to 90kg capacity roaster.

What is the cost of installation and how much time should be allotted?

We will coordinate with you to prepare for and schedule an installation technician who will also make sure your team can independently use the machine when we leave your roastery. In addition to this, we share best practices to help you integrate SÖVDA into your production line as seamlessly as possible. The cost of installation is a flat fee of \$1,500 plus expenses for our technician/trainer. The average time is 3-5 days for install and 1-2 days for training.

How long will it take to receive my Sovda equipment once I place my order?

Depending on the period of the year it may vary. Usually, our lead time is 50 days. And from order to installation time can range from 8 to 16 weeks.

How can I customize my machine?

You have the option to specify any color finish for the Pearl Mini. Simply provide us with the RAL number in the order form to choose a custom color for an additional \$1,000 USD per machine. This could add up to four weeks of production time.

How do I ship my Sovda equipment?

You have two options. You can arrange your own FCA or EXW shipping or let us handle it. We

strongly recommend you ship to your door DDU for \$3,500 USD for all machines or machine packages. Please note this price includes shipping and customs clearance but excludes VAT, taxes and duties. If you arrange shipping, the terms will be FCA and the cost will be \$1500 for us to coordinate with the shipping company.

What are the technical specification requirements for an air compressor?

The recommended specifications for the air compressor are the following: A screw or rotary air compressor with refrigerator type dryer, tank and good filters (oil, dust and water can damage ejectors). You will need 7.5 kw /10hp 23 cfm at 90 psi or .8m3 at .3mpa. You can look at our technical sheet for a comprehensive description of air compressor requirements.

Will the electric be compatible with the service in my country?

Your Pearl Mini will come compatible with the electric you select.

Does the Pearl Mini have a warranty? Can I get a replacement?

SÖVDA equipment comes with a standard one-year parts warranty, labor not included. We want you to be happy with your product. If your machine fails during normal usage and we are not able to get it working again via our customer support team, they will put you in touch with our service team. Our service team will work with you to get you the parts you need for your machine at no cost to you. Warranty doesn't include normal wear items (including filters) or improper use.

S O V D A

Sales@sovdacoffee.com
www.sovdacoffee.com
+1 971-238-2847

Maxime Boegler
Global Sales and Service Director
max@sovdacoffee.com
+ 33 (0)7 82 61 48 72

Nicholas Flatoff
North American Sales & Service
Nick@sovdacoffee.com
+1 503 714 6440