

**BUILT IN BEAN LOADER**  
Effortless loading of beans into the blender.

**ACCESS Lid**  
Rotate in any direction to make access into the blending chamber easy

**TOUCH SCREEN CONTROLS**  
intuitive controls

**Lance & Flex Hose**  
Included standard in base configuration for easy loading

**THREE OUTLET CHUTES**  
Positioned on both sides and on the rear of the machine, these outlet chutes provide ultimate flexibility in floor plan and workflow

Access Doors  
For easy servicing

**1 YEAR WARRANTY**  
with customer support assistance through phone call / email

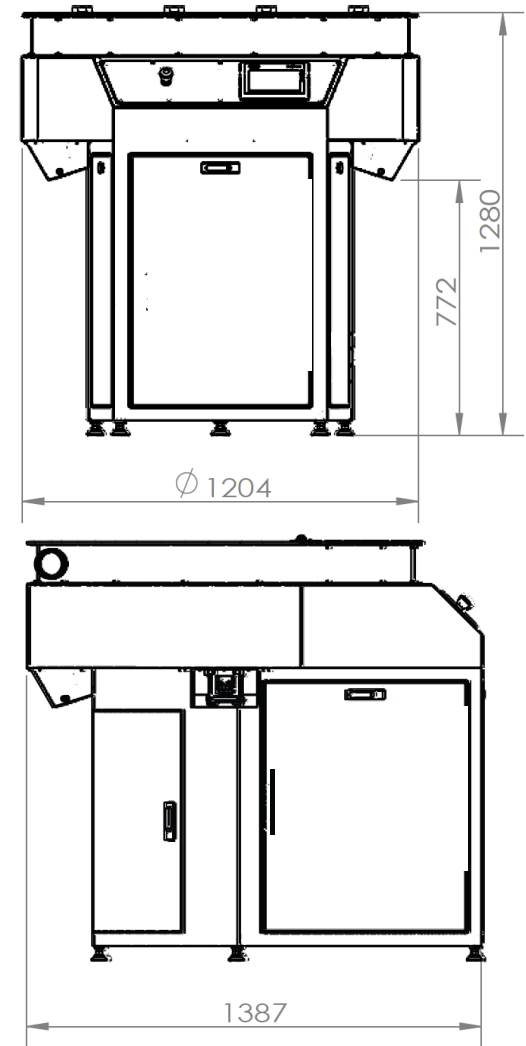

**PRODUCT SPECS**

- Blends up to 200 liters of coffee (~85kg roasted)
- 3 automated outlet chutes compatible with hoppers up to 770mm (~30in) tall
- Integrated vacuum w/ filtration makes loading coffee effortless. Loading speed: 15kg/min.
- Food grade stainless steel and painted metal
- Electric supply: AC 220/240v, 50/60Hz, 1 phase
- Compressed Air: >0.017 M3/h @ 0.4 MPa (0.01CFM @ 60 PSI)