

S O V D A

Receiving, Uncrating & Assembly

Lift

Rev#0.0.1 January 11, 2020

OVERVIEW	2
ORDERING	3
RECEIVING	4
WHAT YOU WILL NEED	5
RECEIVING THE CARGO Receiving the Cargo	5
UNCRATING THE CARGO	7
ASSEMBLING OVERVIEW TS	8

Technical Ambassador:

sales@sovdacoffee.com

+1(971)202-7173

Europe/International

Maxime Boegler
(In Brussels, BE CEST, UTC+1)

China

Sam Pan Yesus
(In Pu'er, China CST UTC+8)

North America

Nicholas Flatoff
(In Portland, USA : PST UTC-8)

INTRODUCTION

Thank you for choosing Sovda for your specialty coffee processing needs! This document establishes details and workflow necessary to simplify the delivery, uncrating, and assembly of your Sovda equipment.

While this document should provide useful information and resources to help you through this process, please feel free to contact your Technical Ambassador if you have any questions about this process.

OVERVIEW

This document will take you through the process of receiving, uncrating, and assembling the Sovda Lift. The Sovda Site Preparation Guide should be followed and the Site Preparation Checklist should be completed prior to receiving your equipment. Once you have completed the uncrating and assembly of your Lift, you will move on to the Lift Commissioning & Training document to get you up and running.

ORDERING

Once you have decided to purchase a piece of Sovda equipment, it's time to submit your order! If you are not already working with a Technical Ambassador, please reach out to Sovda via [this link](#) or using the below QR code:



When you have completed the information form, a Technical Ambassador will contact you and take you through the sales process. An overview of the sales process is listed below:

1. Fill out Information Request Form
2. Schedule a call with your Technical Ambassador to go over order specifics and implementation details
3. Review Quote created by Technical Ambassador
4. When Quote is approved, review Invoice sent by Technical Ambassador
5. Follow preferred payment method information (included in Invoice): either ACH/Wire Transfer/Swift or Credit/Debit Card (fees may apply);
6. Technical Ambassador (in the US) or Logistics Manager (anywhere else) reach out to you to confirm documentation required for shipping your equipment;

7. ~3 weeks prior to the shipping date an invoice for the balance payment will be sent to you.
8. Once you have uploaded the checklists for Site Preparation and Assembly, a Technical Ambassador will reach out to you to schedule installation. Usually there is a 3 to 4 weeks windows from this moment on to the commissioning. At least 3 weeks prior to desired installation date, reach out to your Technical schedule installation with Technical Ambassador

RECEIVING

Once your crate has shipped, you should receive shipping updates from either your Technical Ambassador or a Logistics Manager. LTL (less than truckload) deliveries tend to have a wide delivery window; ensure you are prepared to meet your delivery driver at any point.

Your crate will be large and heavy. Most Liftl orders also include an order for a Sovda Precision Fill or Pearl Mini product; the crate specifics for all products are listed below:

Lift	Precision Fill	Pearl Mini
<ul style="list-style-type: none"> ● LWH ● Weight ● Fastener Types/Needed Tools 	<ul style="list-style-type: none"> ● LWH ● Weight ● Fastener Types/Needed Tools 	<ul style="list-style-type: none"> ● LWH ● Weight ● Fastener Types/Needed Tools

You must ensure you have the following in order to receive the crate:

1. An open area or loading dock where the crate can be removed from the truck;
2. A flat, level path of travel between the unloading area and the assembly area;
3. A forklift or pallet jack to move the crates to the assembly area.

WHAT YOU WILL NEED

UNCRATE

- Pry-Bar
- Hammer
- Work Gloves
- Drill/Impact Gun
- Phillips #2 Screwdriver
- 10mm Wrench or Socket

ASSEMBLY

- 18mm open-ended wrench (or adjustable wrench)
- One pair of Pliers
- #2 Flat-head Screwdriver
- 13mm Wrench or Socket
- 5mm Flex Airline Connection Point

RECEIVING THE CARGO Receiving the Cargo

1. Unload from Truck. Video Intro

Ensure you have adequate space both for the delivery truck to park and for the crate to be removed. If you have a loading dock, direct your delivery driver to use the loading dock.

2. Transporting Crate to Install Location.

Ensure you have a flat, wide path between the unloading location and the desired installation location.

Note: A forklift is recommended for moving the crate, however a pallet jack can be used.

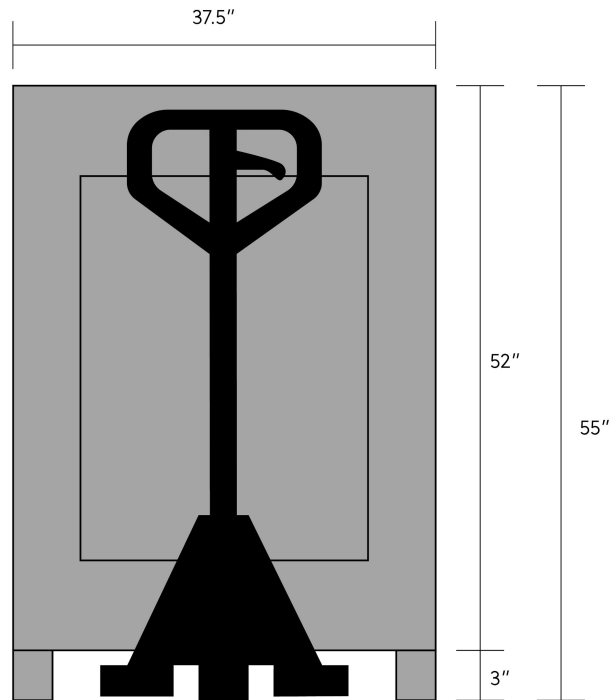

3. Preparation of Install Location.

Ensure you have adequate space to uncrate the machine. We recommend a minimum of 20 square meters/215 square feet of work space dedicated to the uncrate and assembly. **You must also have a forklift able to go up as high as your equipment (i.e 2250mm for the Pearl Mini with base of 250mm, and 2442mm for the Precision fill).**

2 individuals capable of lifting heavy objects and one ladder or equivalent of at least 6 feet (2000mm) high if you will assemble the lift on the Pearl Mini with a 250mm base or on the Precision Fill.

UNCRATING THE CARGO TS0059

Generally, the Sovda Lift will ship in a crate with an easy to open top. The crate will have an interior frame that the top is stapled onto.

Warning: Crate staples are sharp. Take care while removing the lid of the crate to avoid staples and use heavy duty work gloves.

Note: Having a second person to assist with de-crating is recommended.

Note: Before beginning the uncrating process, take photos of the crate including the shock/tilt indicators (if applicable) and any areas of damage to the crate. This will assist if a damage claim needs to be made against shipping insurance.

Work the edge of the pry bar below the top piece of plywood. Tapping the end of the pry bar with a hammer can assist with this step. Once the wedge has enough contact with both parts of the crate, begin prying off the top working from corner to corner.

When three sides have been pried loose, the lid can be tilted upwards which will pull the remaining staples out of the frame.

Note: After removing the top of the crate (but before removing equipment) we recommend taking photos of the equipment including clearances to the crate walls. This will assist if a damage claim needs to be made against shipping insurance.

At this point, equipment can be lifted from the crate with two people. Alternatively, one of the sides of the crate can be removed to make equipment removal easier. Take care to not scratch equipment on screw, nail or staple ends while lifting equipment from the crate.

Ensure you maintain an organized workspace during uncrating to avoid misplacing equipment parts. This will expedite equipment assembly.

Action Required 1 : Send to your technical ambassador any picture of damaged crate

Action required 2 : Find the packing list and perform inventory against the packing list. If there is any piece missing, contact your technical ambassador.

ASSEMBLING OVERVIEW TS

Before getting to connecting parts, let's look at the overview of a Lift in different scenarios. Therefore you will have a general idea how to assemble it. Identify the right situation for you Lift with the right pipe length. The dimension of the pipe will be indicated on the pipe with a marker.

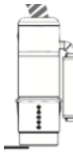

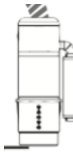
Note : In some drawing the suction system is a vacuum  and in other a central pump box

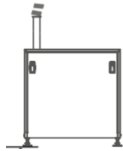

. It does not affect the piping and both are interchangeable.

Standard Lift Overview TS

a. Standard Lift to Pearl Mini

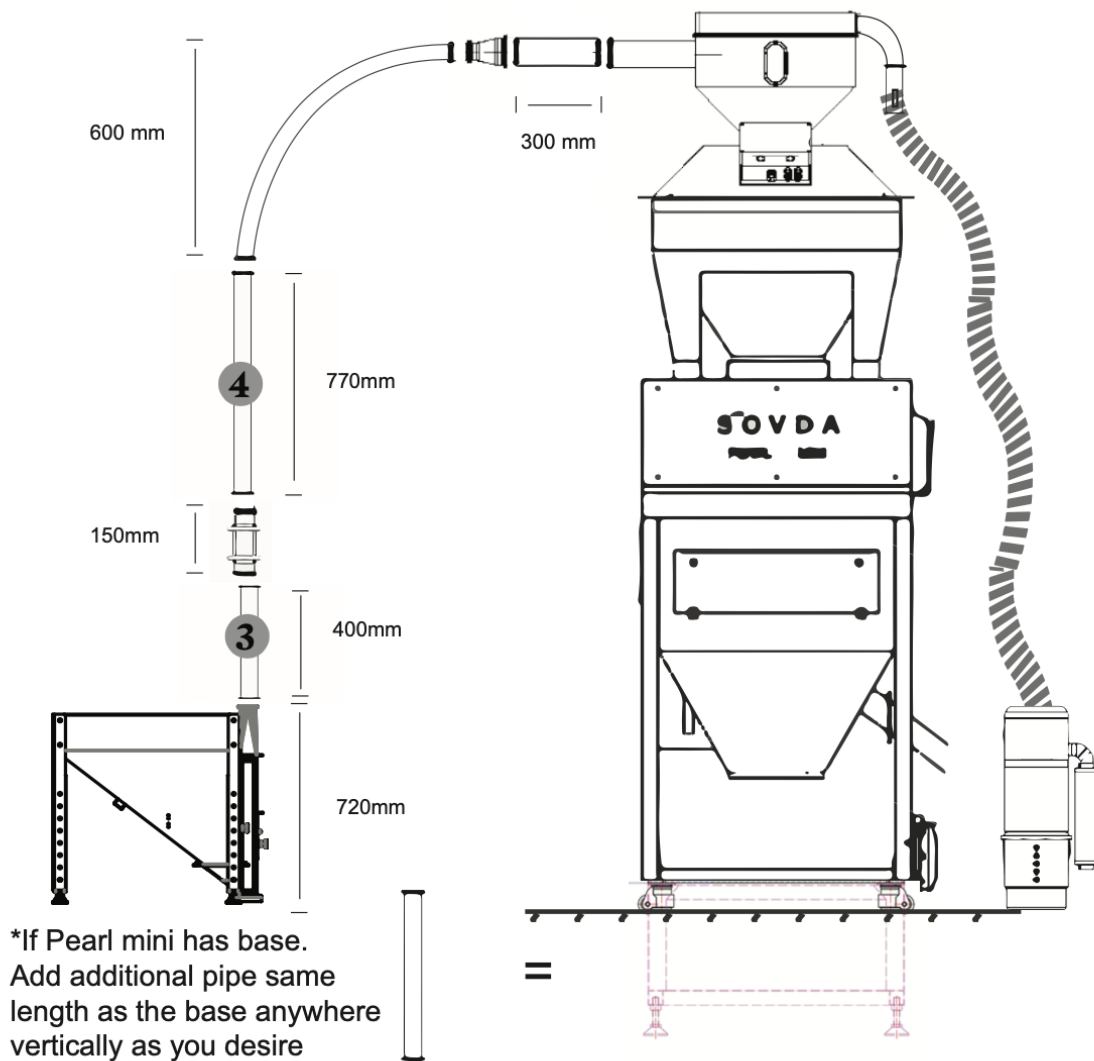

*If Pearl Mini has base, add additional pipe as same length as the base anywhere vertically as you desire.

b. Standard Lift to Precision Fill

First step, adjust Precision Fill's height to 2472mm by adjusting its feet.

b. Standard Lift To Precision Fill

First to adjust Precision Fill's height to 2472mm by adjusting its feet.

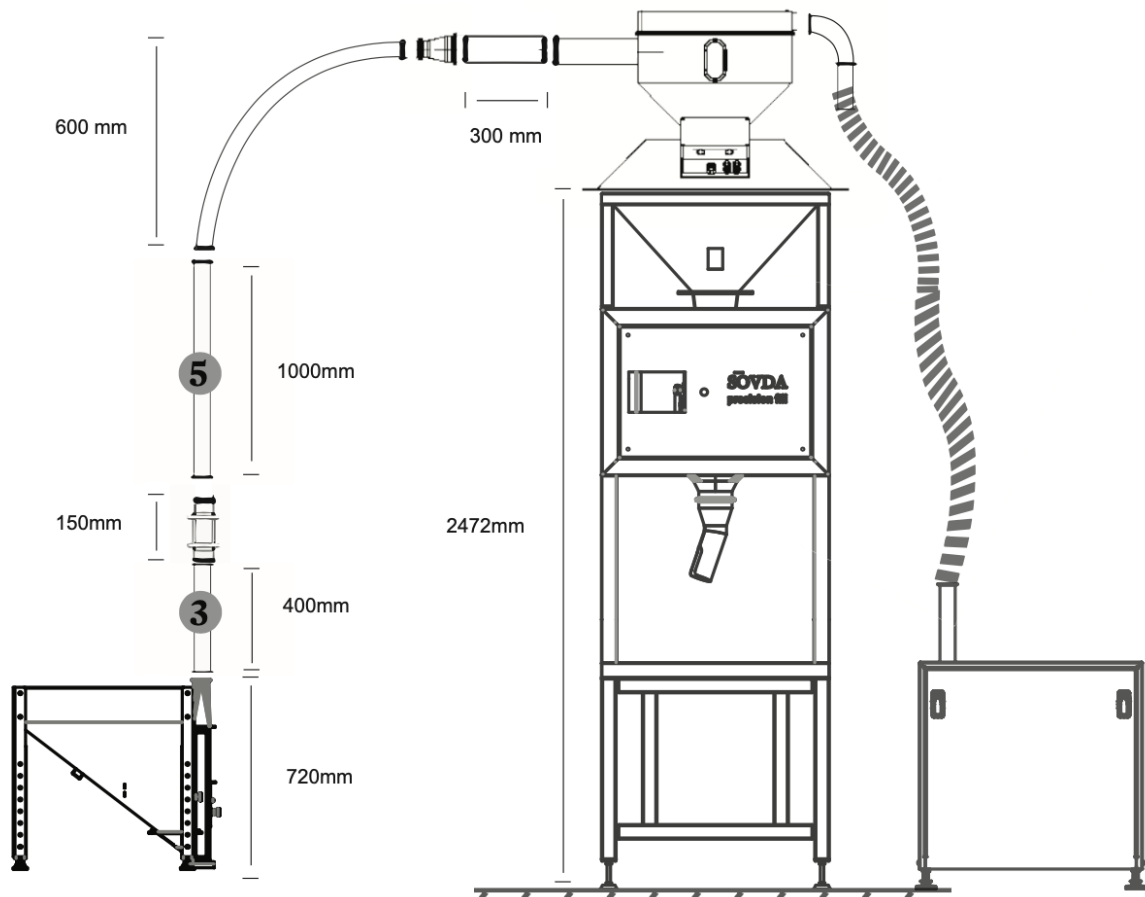

Double Lift Overview (Vacuum and Sovda box are interchangeable)

c.Double Lift to Pearl Mini

Upper outlet 1000mm + sight glass

Lower outlet 770mm + sight glass

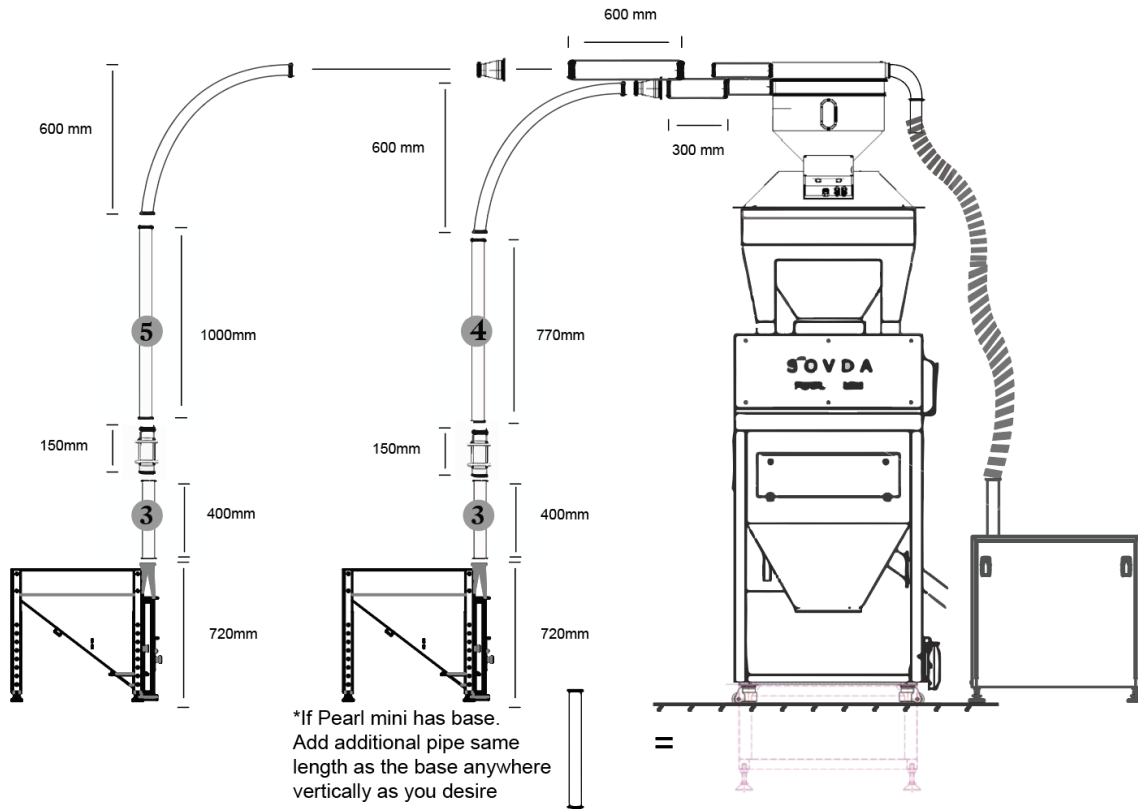

*If Pearl Mini has base, add additional pipe as same length as the base anywhere vertically as you desire.

d.Double Lift to Precision Fill

First to adjust Precision Fill's height to 2472mm by adjusting its feet.

Upper outlet 1230mm + sight glass

Lower outlet 1000mm + sight glass

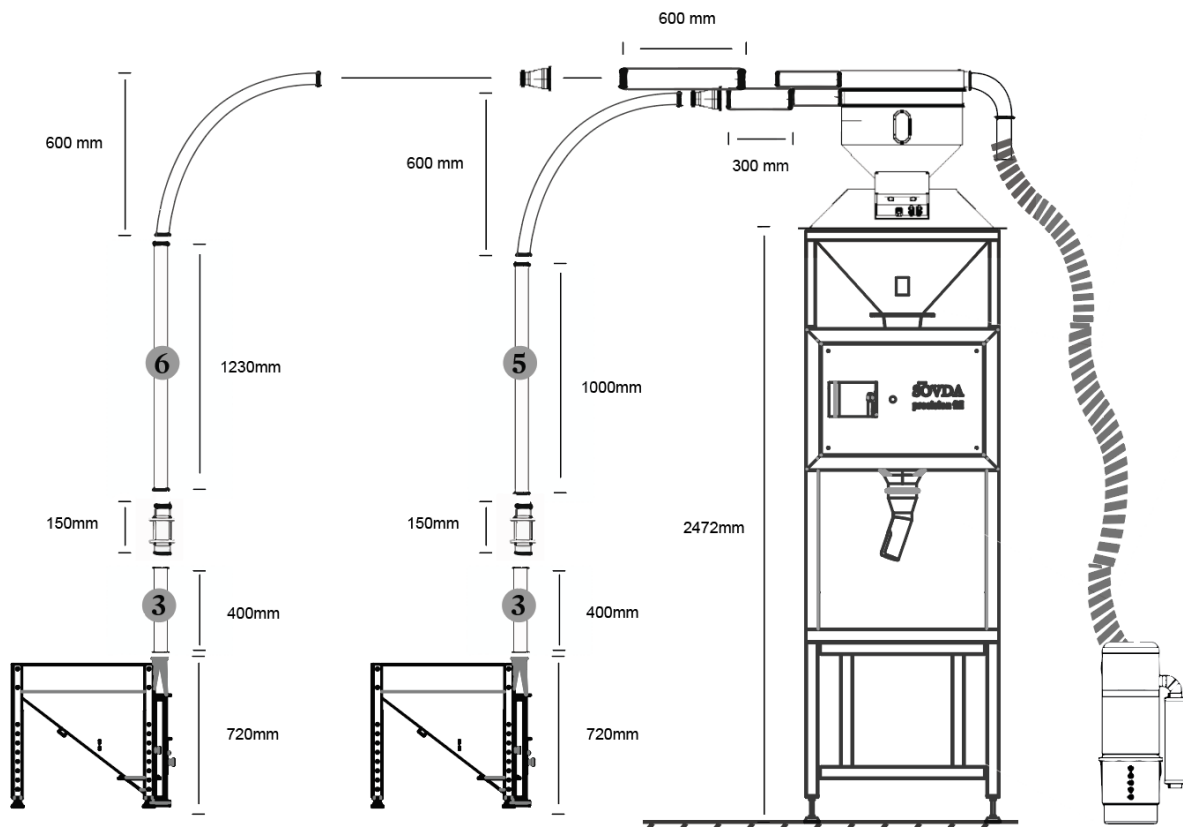

PARTS ASSEMBLY

1. List of parts

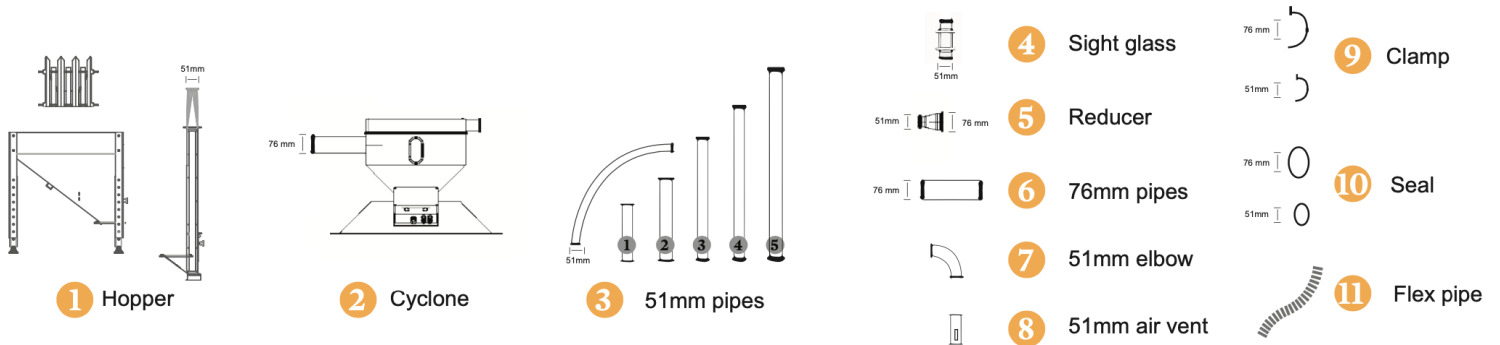

2. Assembling

A. Pipes connecting by Clamps and Seals. Then connect pipes according to the right overview scenario for your lift.

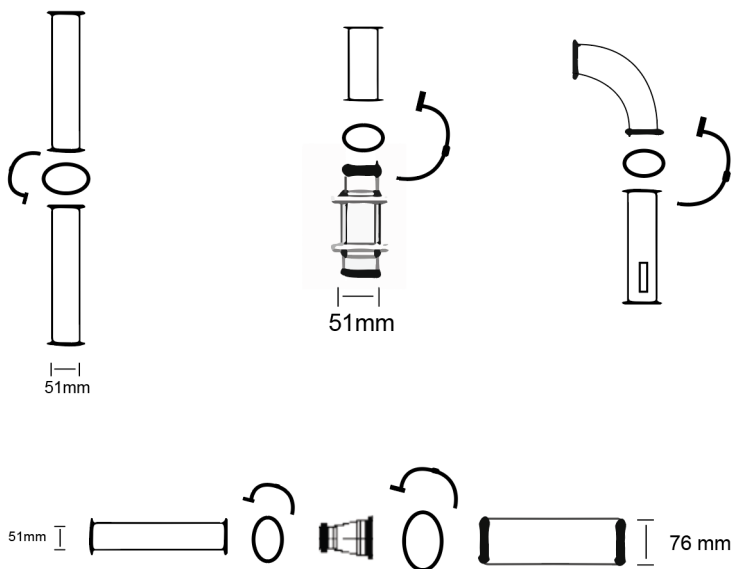

B. Connecting Vacuum or Sovda Box

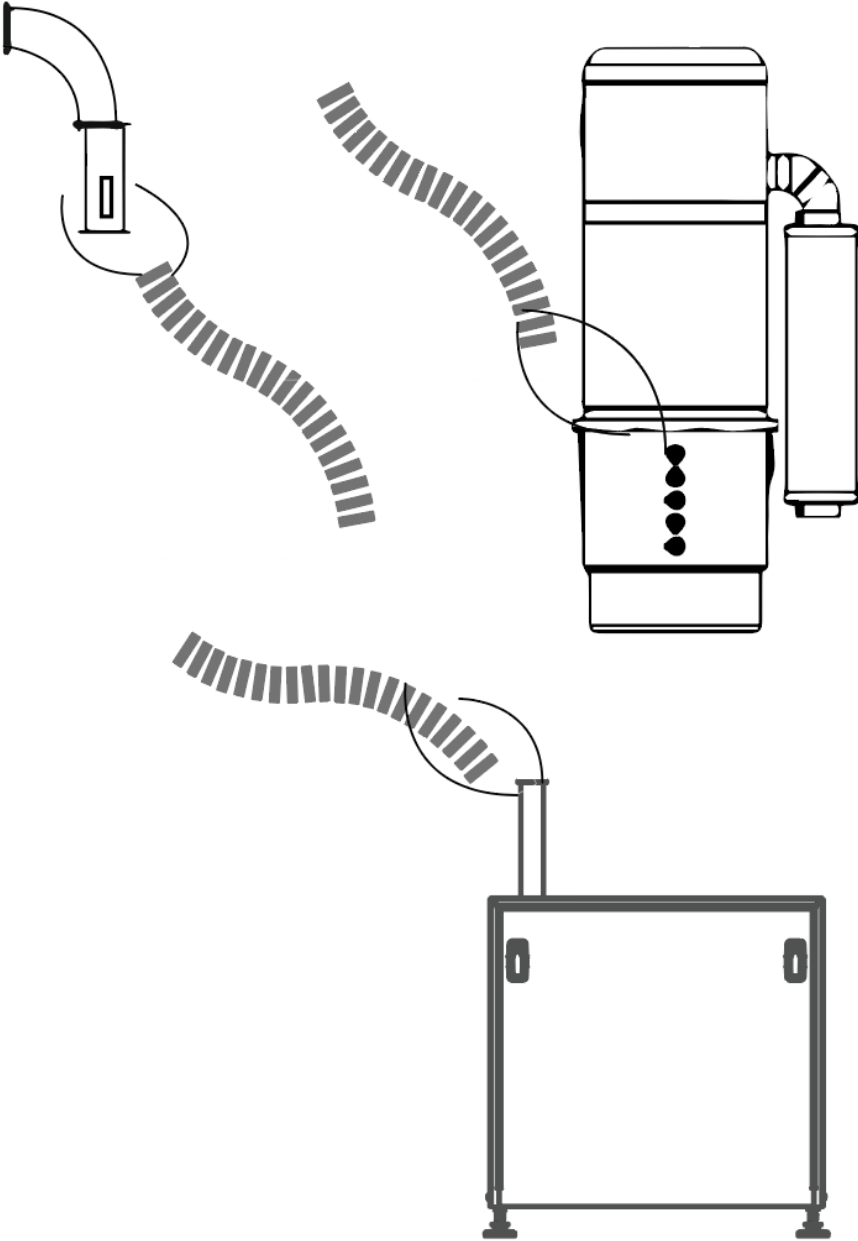

You will connect this part to the butterfly valve on the left see picture.



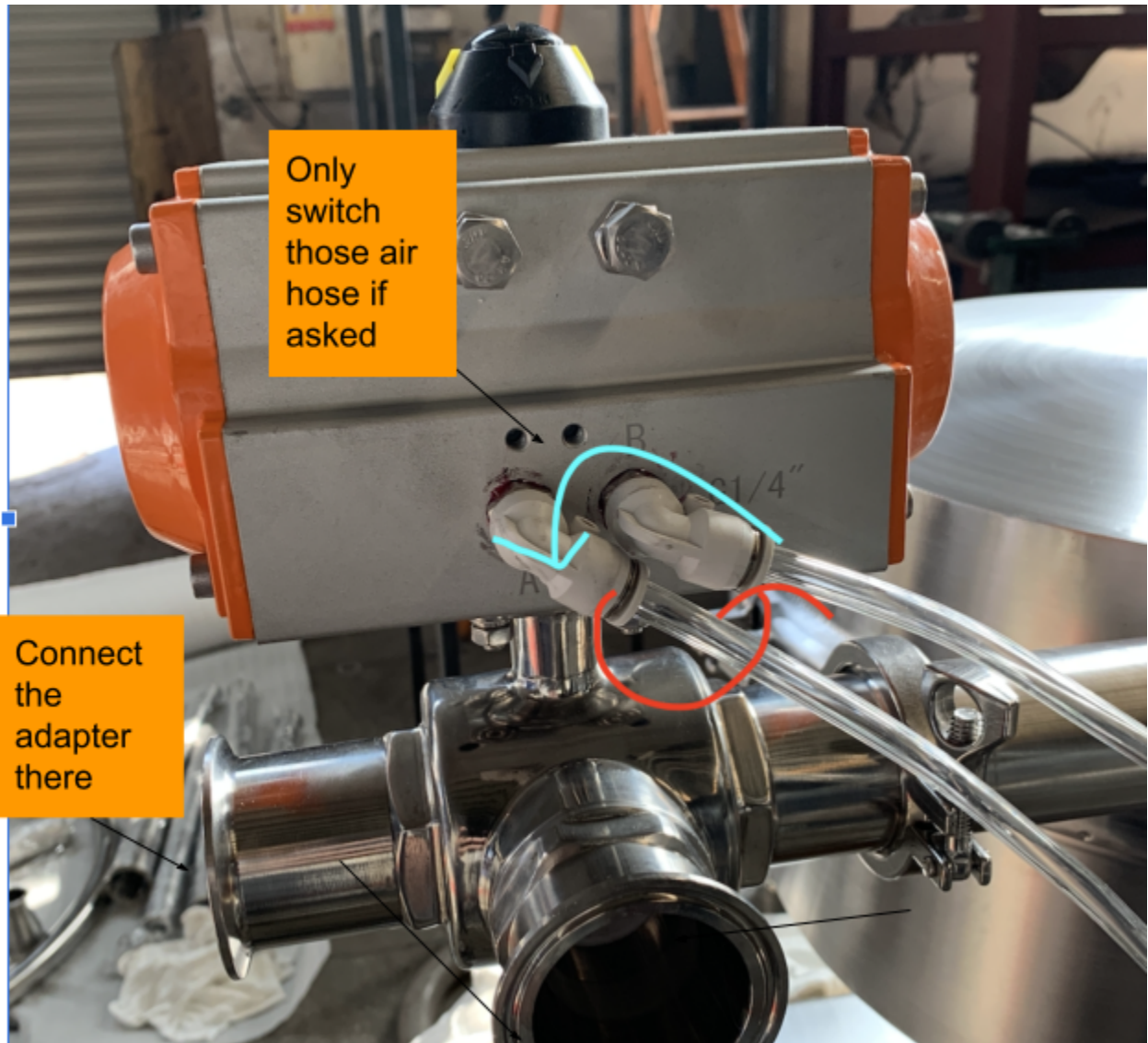

C. Connecting Control Box

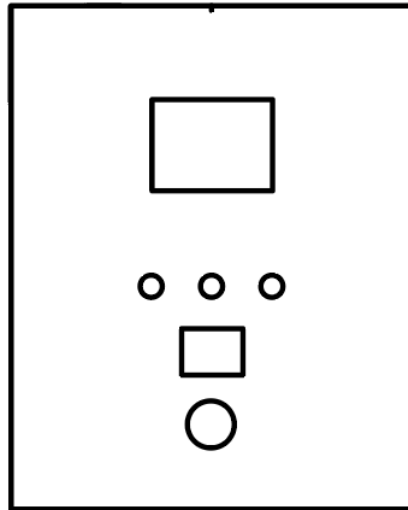

Power
Plug



Solenoid
Plug



Vacuum
Plug

D. Lifting the cyclone on the mounting plate of your equipment

Use a pallet jack if you have one. Or at least 2 strong man and 2 ladders.

Then adjusting the cyclone position according to the position of your hopper.

Watch how to do this in this [video](#) :

E. Assembling the pipe

Make sure you do use the 300mm decelerator (76mm) provided.

If you deviate from the the "standard" layout (as in Standard Layout section) you need to discuss it with your technical ambassador.

Note : You can rotate the hopper in any direction.

F. Connecting Air hose from air compressor to the Air regulator

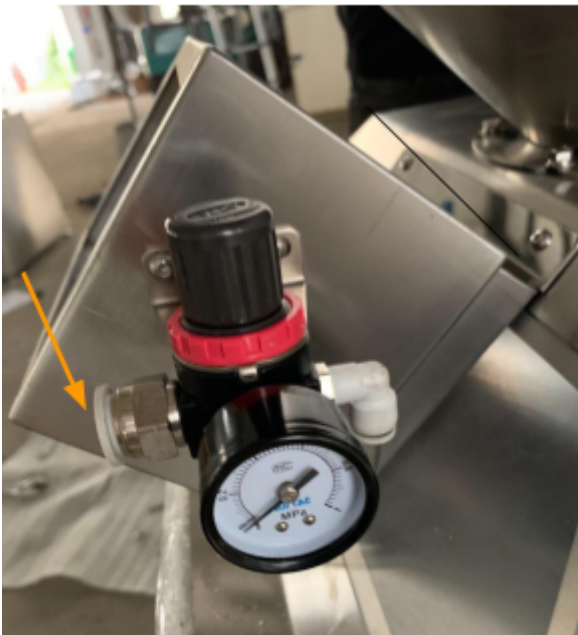

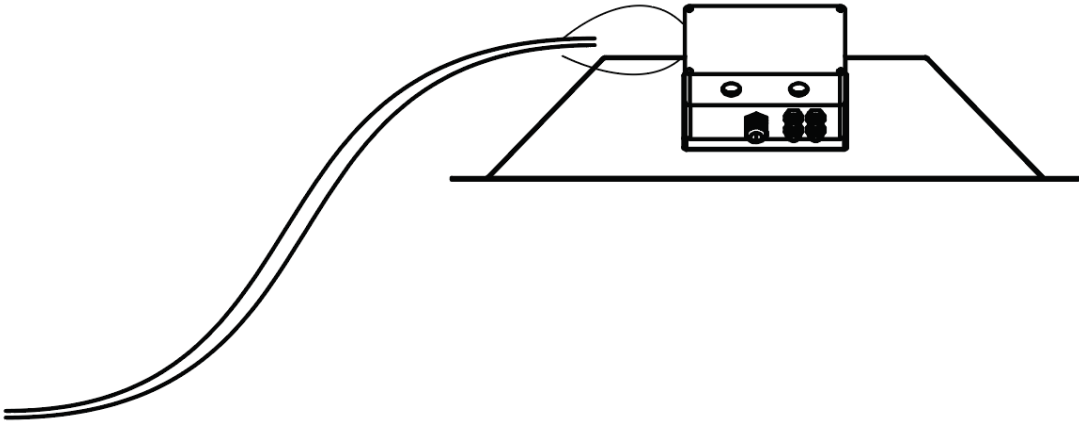

G. Connecting flex pipe to the adapter.



- H. If you have a Lance, connect Lance to the flex pipe, and flex pipe to the R 600mm sweep or lance switch

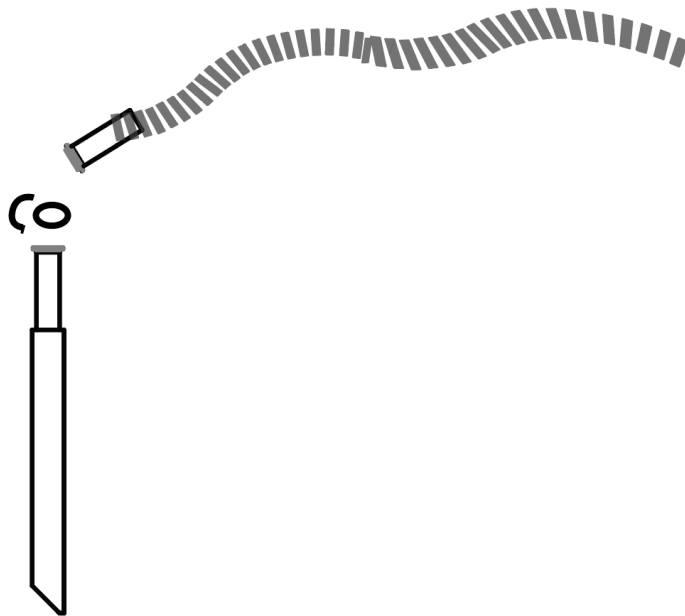

a. R 600mm sweep

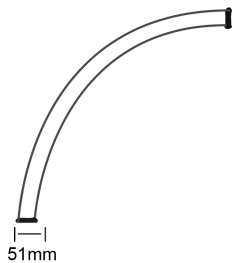

b. Lance switch (Connect to the circle)

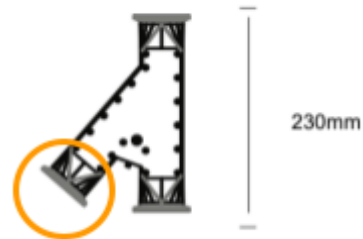

- I. If you have a precision lift, only need to change 400mm pipe to a 320mm pipe
Left is the normal hopper, right is the Precision lift hopper.

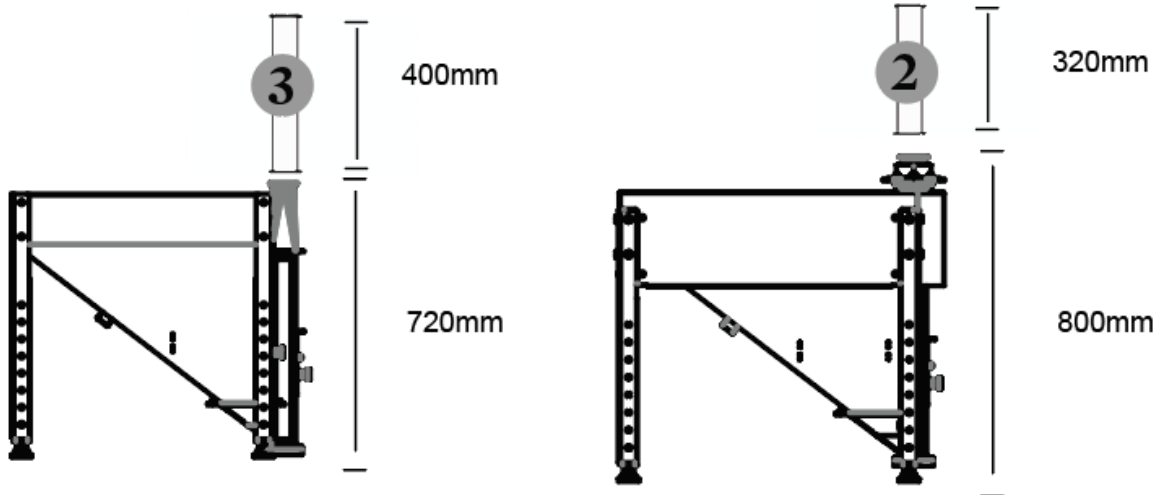

- J. If you have a Lance switch,
 For normal lift, need to change 400mm pipe to a 170mm pipe
 For Precision lift, need to change 320mm pipe to a 90mm pipe

